



## G2SWP SECURITY WALL PACK

## JAYKAL

PROJECT NAME:

**JAYKAL LED SOLUTIONS, INC.**

[www.jaykal.net](http://www.jaykal.net)

PROJECT NOTES:

21499 Baltimore Ave.

Georgetown, DE 19947

(P) 302-295-0015

(F) 302-295-0016

### PRODUCT DESCRIPTION

This Mini Wall Pack combines energy efficiency, customizable lighting options, and durability, making it ideal for outdoor lighting applications where compact size and high performance are essential.

### FEATURES

- Available in 12 Watt or 25 Watt Versions
- CCT Options: 3000K/4000K/5000K/5700K
- Replaces up to 75W HID, 80W Incandescent or 36W CFL
- 5 Year Standard Warranty, 10 Year Optional
- Finish Options: Black, Custom Available
- Optional Photocell



Revised 11/20/24

*Specifications are typical values and may change without notification*

**efficiency. illuminated.**



# G2SWP SECURITY WALL PACK

**JAYKAL**

MODEL	G2SWP
WATTAGE	12W/20W/30W Selectable
LUMENS	1,560/2,600/3,900
EFFICACY	130lm/W
INPUT VOLTAGE	120-277VAC 50/60Hz
POWER FACTOR	>0.9
SURGE PROTECTION	2KV
CRI	>80
CCT	3000K/4000K/5000K Selectable
LIFE(L70)	50,000+ hours
BEAM ANGLE	100°
DRIVER EFFICIENCY	≥85%
DRIVER CLASS	Class II
DIMMING	0-10V
0-10V SINK CURRENT	<1mA
ENVIRONMENT	Wet Locations
IP RATING	IP65
HOUSING FINISH	Bronze
LENS MATERIAL	Polycarbonate
WARRANTY	5 Year / 10 Year Option
WEIGHT	1.98 lbs./ 0.9 Kgs.
DIMENSIONS	8.19 X 5.51 X 3.54 in.
FCC	FCC Title 47 CFR Part 18 compliance
SAFETY CERTIFICATIONS	ETL

## DIMENSIONS (Unit : mm/Inches)

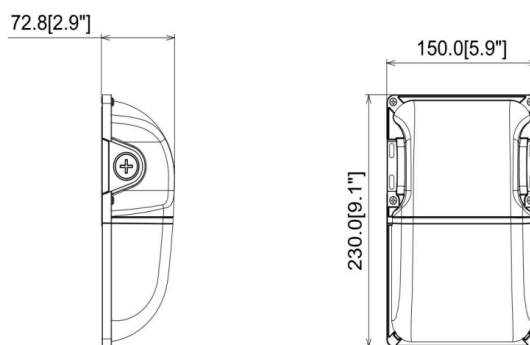

ORDERING GUIDE					JLS-G2SWP-M1-MCCT-BR-PC				
MODEL	-	WATT	-	CCT	-	HOUSING	-	OPTIONS	
JLS-G2SWP		M1 = 15W/20W/30W		MCCT = 3000K/4000K/5000K		BR = Bronze		N = No option PC = Photocell	

*Specifications are typical values and may change without notification*

**efficiency. illuminated.**