



G2 Solar Street Light

JAYKAL

PROJECT NAME:

JAYKAL LED SOLUTIONS, INC.

www.jaykal.net

PROJECT NOTES:

21499 Baltimore Ave.

Georgetown, DE 19947

(P) 302-295-0015

(F) 302-295-0016

DESCRIPTION

G2SS is a series of small to medium-power Solar Street Lights with design that is both practical and aesthetically pleasing.

Whole G2SS series have passed Solar Street Light UL8801 certification.

Housing adopt ADC12 Aluminum heat sink, outdoor powder coating.

The solar panels are made from power station level photovoltaic panels, providing higher photoelectric conversion efficiency and Important materials have UL certification.

Utilizing automotive-grade lithium batteries which have a longer lifespan and greater capacity, enabling the lights to operate normally even during consecutive rainy days, the battery cells have UL certification.

Additionally, the lights have a professional optical lens design that directs the light to the ground, rather than leaving it suspended in the air.

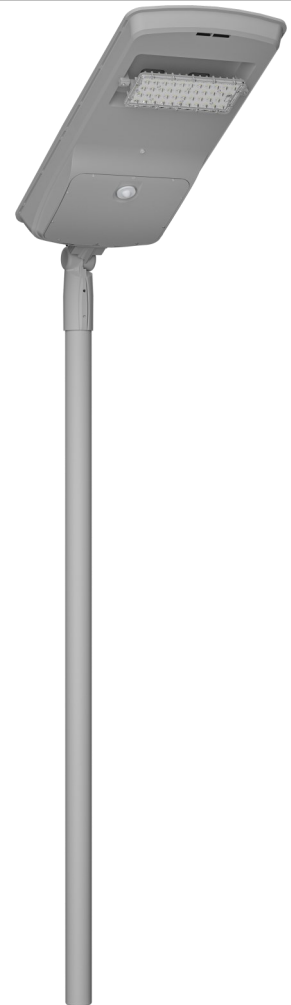

FEATURES & BENEFITS

- ◆ Wattage: 8W/20W/30W
- ◆ CCT Options: 3000K/4000K/5000K/5700K
- ◆ Built in MPPT controller
- ◆ Near Zero Maintenance
- ◆ LiFePO4 Battery



Revised 5/8/24

(P) 302-295-0015 | (E) sales@jaykal.net | (W) www.jaykal.net

Specifications are typical values and may change without notification

Revised 5/8/24

efficiency. illuminated.



G2 Solar Street Light

JAYKAL

SPECIFICATIONS

MODEL	JLS-G2SS-8W	JLS-G2SS-20W	JLS-G2SS-30W
WATTAGE	8W	20W	30W
POWER OF PV MODULE(W)	17	36	52
LITHIUM BATTERY CAPACITY	9Ah/115.2Wh	18Ah/230.4Wh	30Ah/384Wh
INFRARED SENSOR	Yes	Yes	Yes
CONTROL TYPE	MPPT	MPPT	MPPT
OPTICAL DISTRIBUTION	T3	T3	T3
BEAM ANGLE	140°×70°	140°×70°	140°×70°
LUMEN (LM)	1600	4000	6000
CCT	3000K/4000K/5000K/5700K		
MIN WORKING TIME (HOURS) - BRIGHT MODE(80%)	18	14.5	16
MIN WORKING TIME (HOURS) - DIM MODE(80%)	72	57.5	64
EPA(FT2)	1.28	2.21	2.83
WIND LOAD RATE(MPH)	130	130	130
WEIGHT (KG)	5.27	9.7	13.5
DIMENSION (MM)	518.8(L)×290(W)×84.2(H)	677.7(L)×420(W)×98.6(H)	917.8(L)×420(W)×98.6(H)
WORKING MODE	80% brightness when motion is detected, 20% brightness when no motion is detected		
CHARGING TEMPERATURE	0℃~60℃		
DISCHARGING TEMPERATURE	-20℃~60℃		
CCT	3000K/4000K/5000K/5700K		
OPERATIONAL TEMP.	-30° C - 45° C (-22° F - 113° F)		
HOUSING MATERIAL	ADC12 Aluminum		
IP RATING	IP65		
IK RATING	IK08		
HOUSING FINISH	Grey / Brown		
WARRANTY	5 Years		
CERTIFICATION	UL8801		

ORDERING GUIDE

EXAMPLE: JLS-G2SS-30-50K-G-T3-SF

MODEL	WATTAGE	CCT	FINISH	LENS DISTRIBUTION	MOUNTING OPTIONS
JLS-G2SS	8 = 8W 20 = 20W 30 = 30W	30K = 3000K 40K = 4000K 50K = 5000K 57K = 5700K	G = Grey B = Brown	T3 = Type III	SF = Slip Fitter Mount (Default) SP = Square Pole Mount WM = Wall Mount

(P) 302-295-0015 | (E) sales@jaykal.net | (W) www.jaykal.net

Specifications are typical values and may change without notification

efficiency. illuminated.



G2 Solar Street Light

JAYKAL

DIMENSIONS (Unit : mm)

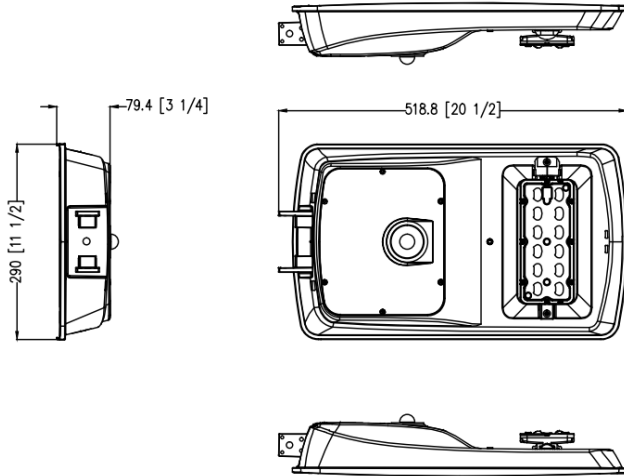

8W

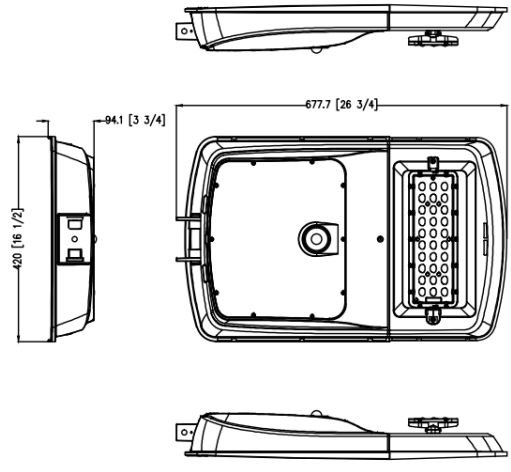

20W

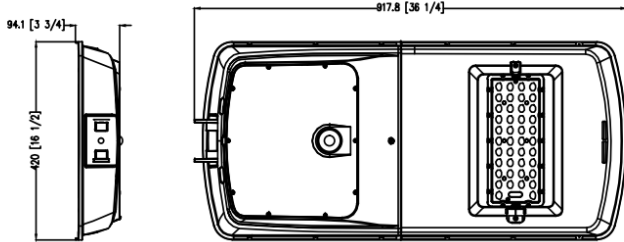

30W

(P) 302-295-0015 | (E) sales@jaykal.net | (W) www.jaykal.net

Specifications are typical values and may change without notification

efficiency. illuminated.

G2 Solar Street Light



JAYKAL

MPPT CONTROLLER

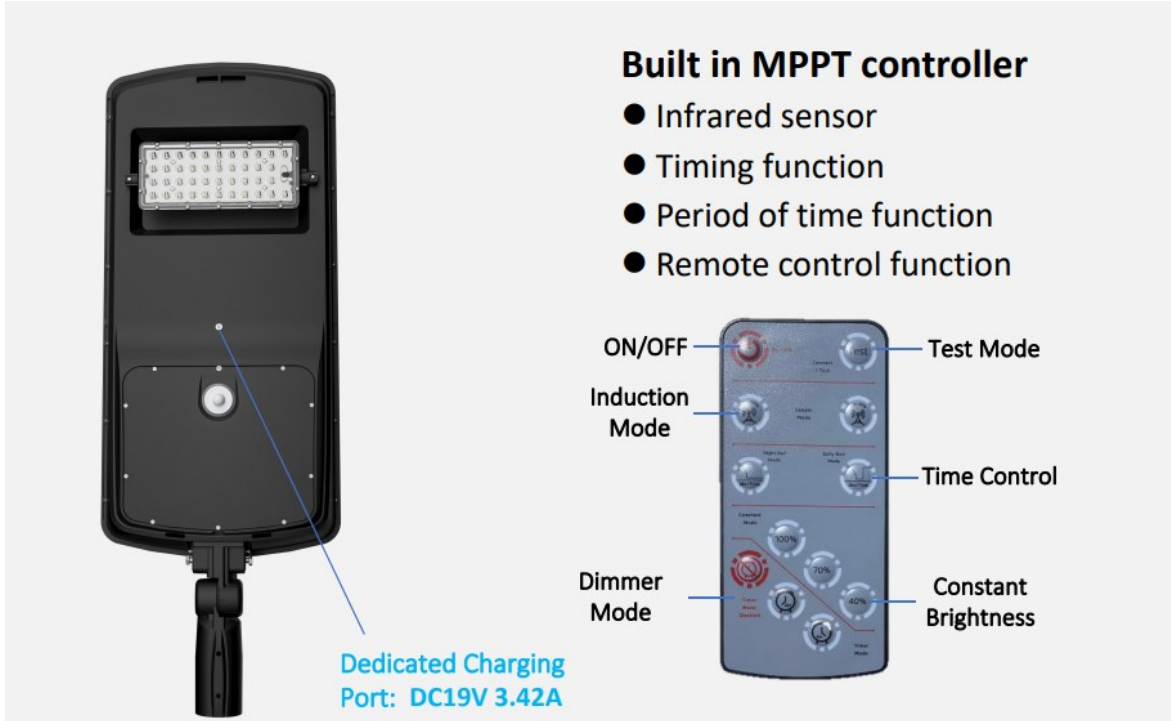

(P) 302-295-0015 | (E) sales@jaykal.net | (W) www.jaykal.net

Specifications are typical values and may change without notification

efficiency. illuminated.



G2 Solar Street Light

JAYKAL

MOUNTING OPTIONS

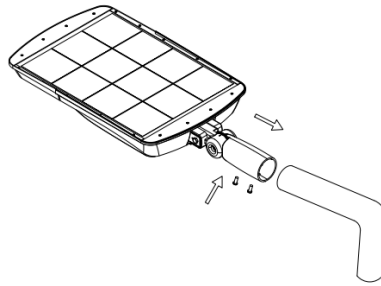

Option 1 : Slip Fitter Mount

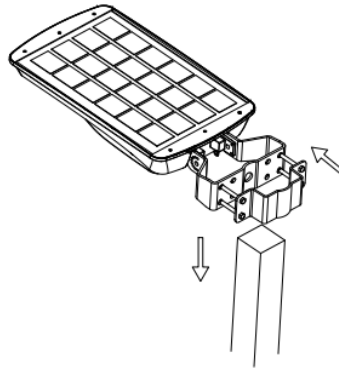

Option 2 : Hoop Mount

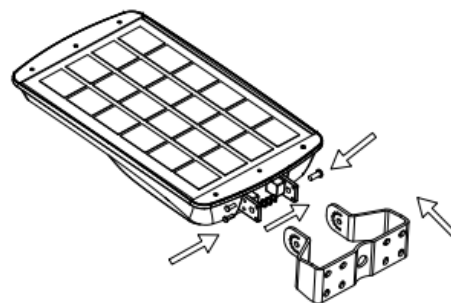

Option 3 : Wall Mount

(P) 302-295-0015 | (E) sales@jaykal.net | (W) www.jaykal.net

Specifications are typical values and may change without notification

efficiency. illuminated.