

300W-1200W G3 FLOOD LIGHT



JAYKAL

PROJECT NAME:

JAYKAL LED SOLUTIONS, INC.

www.jaykal.net

PROJECT NOTES:

21499 Baltimore Ave.

Georgetown, DE 19947

(P) 302-295-0015

(F) 302-295-0016

OVERVIEW

The all new toolless modular design allows for easy individual tilt adjustment or complete replacement of the modules. Each module is adjustable +/- 30° and optional light shields are available per module. Our laser aiming tool greatly shortens installation time.

FEATURES

- ◆ Wattages: 300W/600W/900W/1200W
- ◆ Lumen Package: 150lm/W
- ◆ Toolless Modular Design
- ◆ +/- 30° Rotational Angle for Individual Modules
- ◆ Available with 100-277VAC / 200-480VAC Input
- ◆ Cast Aluminum Construction Provides Superior Cooling
- ◆ Excellent Optical Design Optimizes Light Utilization and Distribution.
- ◆ 0-10V Dimming (Option)
- ◆ Beam Angles Available: 10°/30°/60°/90°/120°/150°*60°/ 20°*30°/ 130°*30°/WB-P60°/T3-VS



RoHS 
Compliant

Revised 4/27/23





Specifications are typical values and may change without notification

efficiency. illuminated.

300W-1200W G3 FLOOD LIGHT

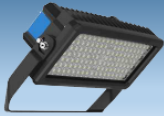

JAYKAL

				
Model	G3FL-300	G3FL-600	G3FL-900	G3FL-1200
WATTAGE	300W	600W	900W	1200W
INPUT VOLTAGE	100-277VAC / 200-480VAC 50/60 Hz			
SURGE PROTECTION	20KV			
DIMMING (OPTIONAL)	0-10V			
OPERATING TEMPERATURE	-40°C to +50°C			
POWER FACTOR (PF)	>0.95			
DRIVER EFFICIENCY				
THD	<15%			
EFFICACY @ 85 CRI	150LM/W			
LUMEN OUTPUT (+/- 5%)	45,000lm	90,000lm	135,000lm	180,000lm
BEAM ANGLE	10°/30°/60°/90°/120°/150°*60° / 20°*30° / 130°*30°/WB-P60°/T3-VS			
BUG RATING				
L70 HOURS	>50,000			
CRI	>70			
CCT	3000K / 4000K / 5000K / 5700K/6500K			
IP RATING	IP66			
HOUSING MATERIAL	Die-cast Aluminum			
LENS MATERIAL	Polycarbonate			
INSTALLATION TYPES	Trunnion Mount Kit / Knuckle Mount Slip Fitter Kit			
Accessories (Optional)	Motion Sensor			
Housing Color	Black			
DIMENSIONS	9.06L X 19.49W X 7.40D in.	16.06L X 22.05W X 8.58D in.	22.83L X 22.44W X 12.79D in.	30.31L X 22.24W X 12.79D in.
GROSS WEIGHT	16.06 lbs.	30.8 lbs.	41.8 lbs.	55 lbs.
Certifications	UL,CE,ROHS			
FCC Compliance	FCC 47, CFR Part 18			

ORDERING GUIDE

EXAMPLE: JLS68103-G3FL-300-277-40K-30-B-TM-PC

MODEL	-	WATTAGE	-	VOLTAGE	-	CCT	-	OPTICS	-	FINISH	-	MOUNT	-	OPTIONS
JLS68103-G3FL		300 = 300W 600 = 600W 900 = 900W 1200 = 1200W		277 = 120-277VAC 480 = 200-480VAC		30K = 3000K 40K = 4000K 50K = 5000K 57K = 5700K 65K = 6500K		10 = 10° 30 = 30° 60 = 60° 90 = 90° 120 = 120° 130 = 130° X 30° 150 = 150° X 60° 23 = 20° X 30° WB = WB-P30° T3 = T3-VS		B = Black		TM = Trunnion Mount KM = Knuckle Mount		Blank = No Option PC = Photocell LS = Lighting Shield LA = Laser Aiming tool

Specifications are typical values and may change without notification

efficiency. illuminated.

300W-1200W G3 FLOOD LIGHT



JAYKAL

ACCESSORIES

ACCESSORIES

G3FL-LASER

Laser aiming tool speeds installation by simplifying the alignment of the optics.

LASER AIMING TOOL

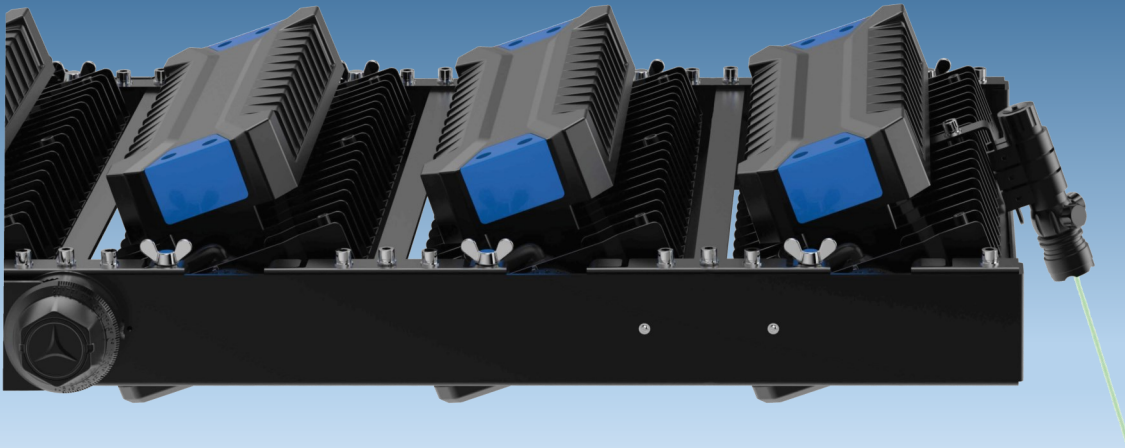

SHIELD

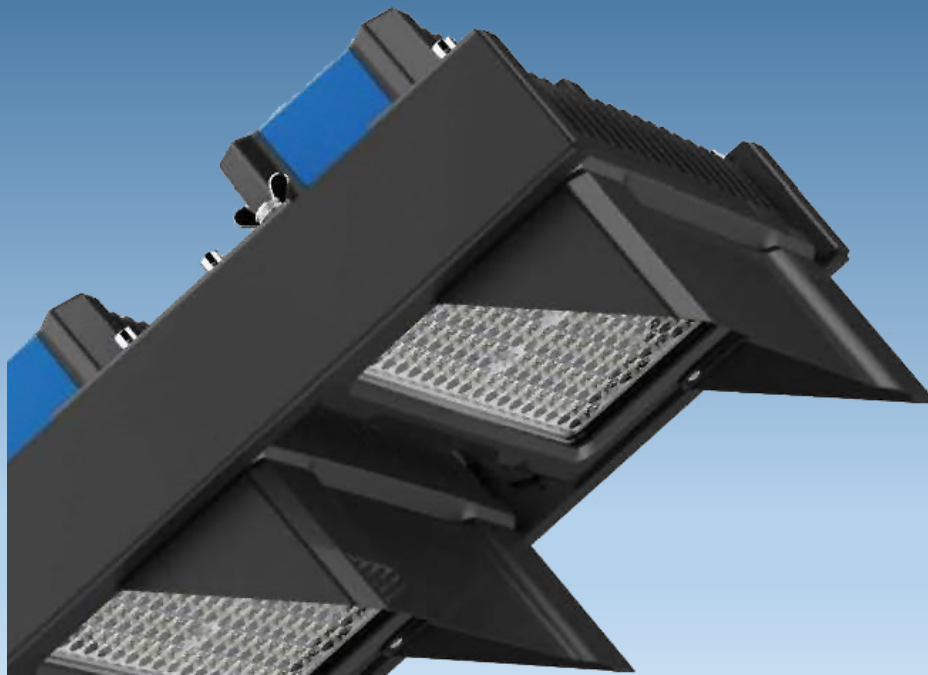

Specifications are typical values and may change without notification

efficiency. illuminated.

300W-1200W G3 FLOOD LIGHT



JAYKAL

FEATURES

+/- 30° ADJUSTMENT FOR EACH MODULE



TWO MOUNTING OPTIONS

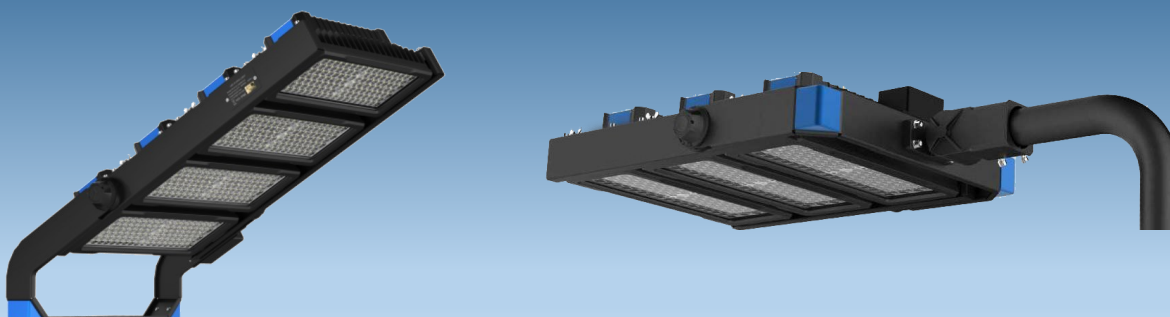

TRUNNION MOUNT

KNUCKLE MOUNT SLIP FITTER

Specifications are typical values and may change without notification

efficiency. illuminated.