



SENSOR READY G2WRAP-S LUMINAIRE

JAYKAL

PROJECT NAME:

JAYKAL LED SOLUTIONS, INC.

www.jaykal.net

21499 Baltimore Ave.

Georgetown, DE 19947

(P) 302-295-0015

PROJECT NOTES:

PRODUCT DESCRIPTION

Jaykal's new sensor ready design enables sensors to be installed by simply plugging in the sensor. If no controls are needed now, they may be added later, with a simple plugin installation. The fixture is suitable for commercial and retail applications.

Wattage and color selectability is standard, allowing field tuning to meet changing project requirements. It features three wattage presets and three color presets and is DLC listed.

FEATURES

- Available in 16W to 48W Multi-Wattage Driver
- CCT: 3500K/4000K/5000K Selectable
- 115 lm/W
- 0-10V Dimming
- 5 Year Standard Warranty

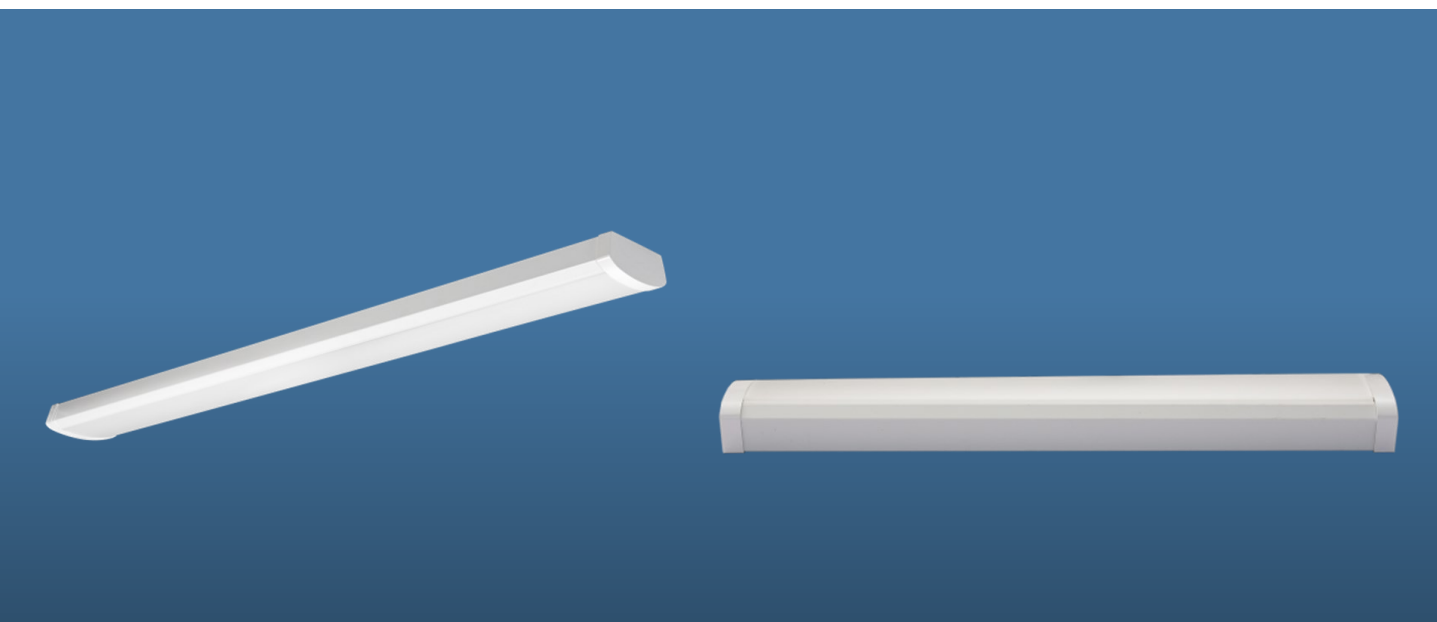

RoHS 
Compliant



Revised 10/4/24

Specifications are typical values and may change without notification

efficiency. illuminated.



SENSOR READY G2WRAP-S LUMINAIRE

JAYKAL

SPECIFICATIONS TABLE		
MODELS	JLS-G2WRAP-S	
INPUT VOLTAGE	120-277VAC 50/60hz	
LENGTHS	2FT	4FT
WATTAGE TYPE	M1	M1
WATTAGE	16W/20W/24W	32W/40W/48W
EFFICACY	115lm/W	
LUMENS	1,840/2,300/2,760	3,680/4,600/5,520
L70 HOURS	100,000 hrs. +	
POWER FACTOR	>0.9	
THD	<20%	
INTEGRATED EM DRIVER	8W	
CRI	80	
CCT	MCCT (3500K/4000K/5000K Selectable)	
OPERATIONAL TEMP.	-30°C (-22°F) - 45°C (113°F)	
HOUSING MATERIAL	Steel	

DIMENSIONS (Unit : mm/Inch)

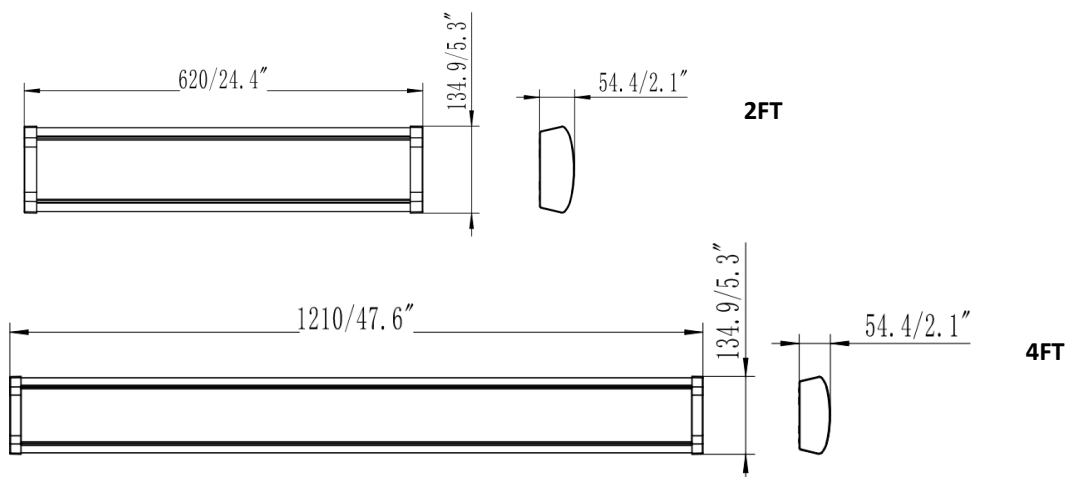

Ordering Guide

MODEL	SIZE	WATTAGE	CCT	EMERGENCY	TAA
JLS-G2WRAP-S	2 = 2FT	M1 = 16W/20W/24W	MCCT = 3500K/4000K/5000K	N = None EM = 8W Integrated	[TAA] = Laos
	4 = 4FT	M2 = 32W/40W/48W			

Specifications are typical values and may change without notification

efficiency. illuminated.



SENSOR READY G2WRAP-S LUMINAIRE

JAYKAL

Compatible Controls Guide

BRAND	MODEL	SENSOR TYPE
LumaLinx	JLS-LL-IFS06R	ESSENTIAL
LumaLinx	JLS-LL-RM-51	REMOTE CONTROL PROGRAMMER
LumaLinx	JLS-LLE-IFS108.C1	ENHANCED

Specifications are typical values and may change without notification

efficiency. illuminated.