

JAYKAL LED GAS STATION LIGHT



JAYKAL

Installation Procedures

PRODUCT APPLICATIONS

Jaykal's LED Gas Station Canopy Lights are an excellent solution for all types of canopy lighting needs. The large footprint makes it easy to retrofit and conceal cosmetic issues created when removing existing fixtures.

NOTE:

NEW refers to mounting a new/replaced canopy skin.

REPLACEMENT refers to the complete removal and replacement of an existing fixture.

LUMINAIRE is a complete lighting unit, not a replacement lamp.

IMPORTANT: A licensed electrician must disconnect the primary power from the circuit connected to the fixture, and provide any lockout tags on the breakers or switches as required by the electrical code.



STRUCTURAL FEATURES:

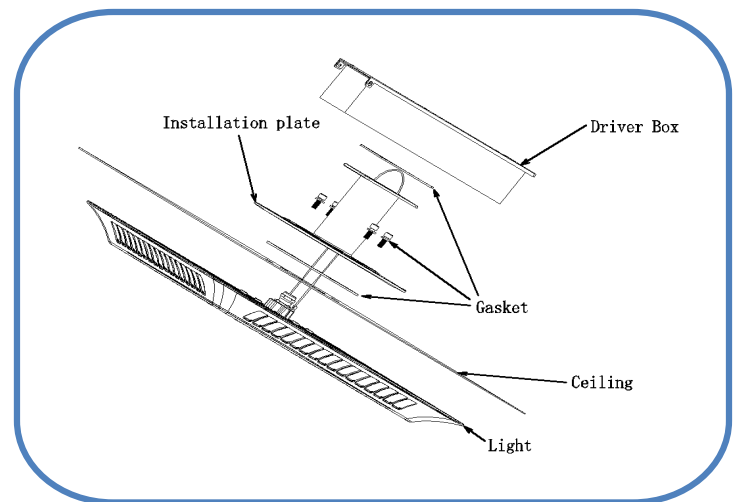
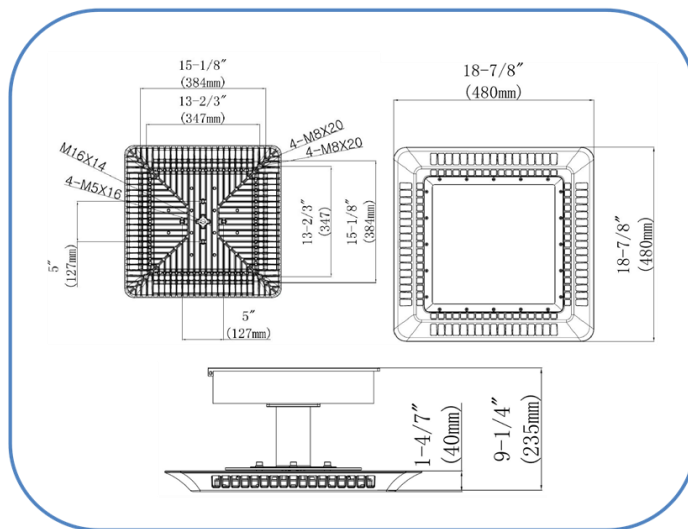

(P) 302-295-0015 | (E) sales@jaykal.net | (W) www.jaykal.net

efficiency. illuminated.

JAYKAL LED GAS STATION LIGHT



JAYKAL

New Installation

Begin by marking your drill hole locations. (See Figure 2). When you have completed marking your locations, drill the 2 inch (50mm) hole and the four 1/2 inch (12mm) holes. The 2 inch hole represents the physical center of the canopy fixture and provides routing for the electrical connections to the LED driver which will be installed above the canopy. The four 1/2 inch holes allow the mounting bolts to secure the upper and lower sections of the fixture to the canopy.

New:

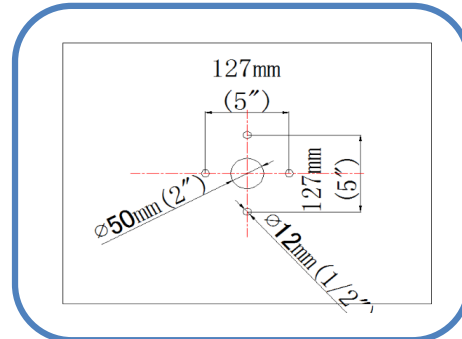
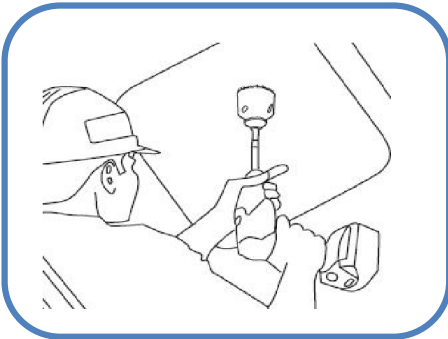

Replacement:

Disconnect wiring from the old fixture and remove fixture from canopy.

Clean installation area:

Clean surface with a cloth and cleaning agent. Continue with Step 1 of New Installation.

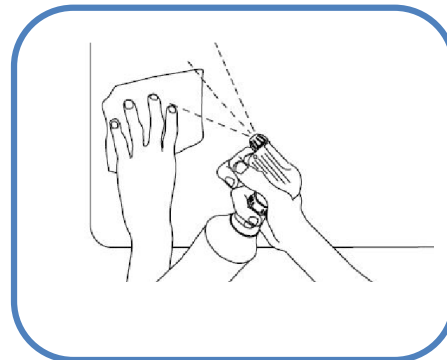
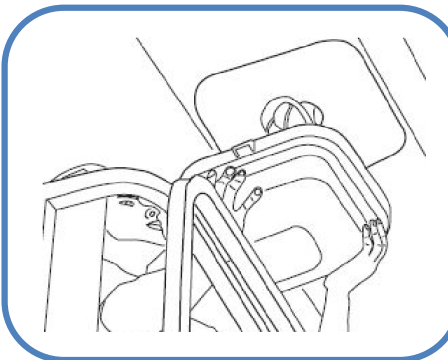

JAYKAL LED GAS STATION LIGHT



JAYKAL

A. EMBEDDED FIXTURE INSTRUCTIONS:

Step 1:

Mount the fixture with hanger cable/metal rod and hang as a pendant.

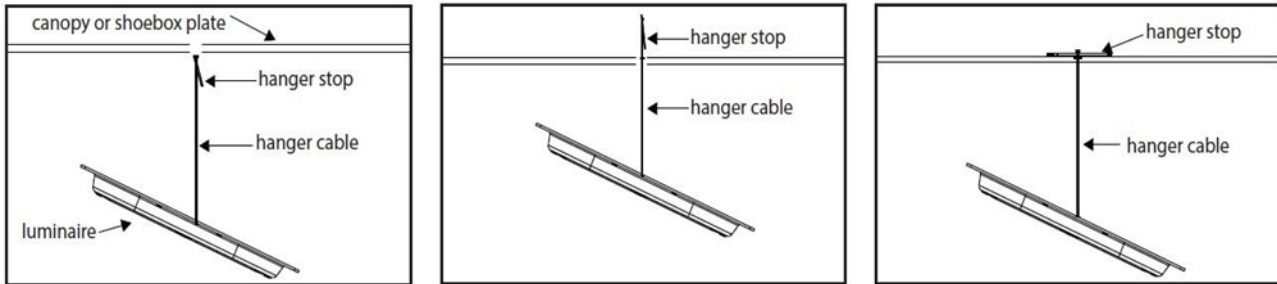

Step 2:

Place water proof gasket below the bracket. Once aligned over 4 M8 holes on the back of the luminaire, affix the screws.



Step 3:

Install the gasket to the bottom of the driver box and top of the bracket. Secure with screws.



Step 4:

Route luminaire input DC to the DC and AC to AC (red to red and black to black). Turn on the system and breaker to ensure proper luminaire operation.

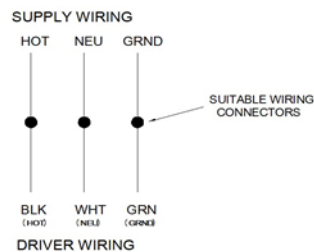

JAYKAL LED GAS STATION LIGHT



JAYKAL

A. SURFACE MOUNTED FIXTURE INSTRUCTIONS:

Step 1:

Install the frame in the ceiling.

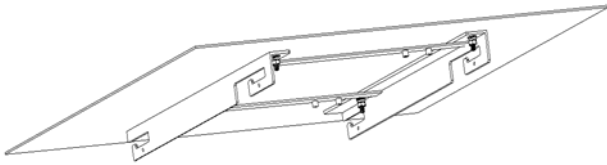

Step 2:

Place the driver box assembly into frame and connect to the AC input.

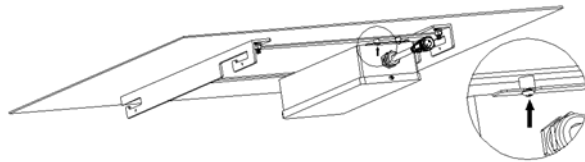

Step 3:

Attach the bracket over the luminaire and secure using the screws provided.

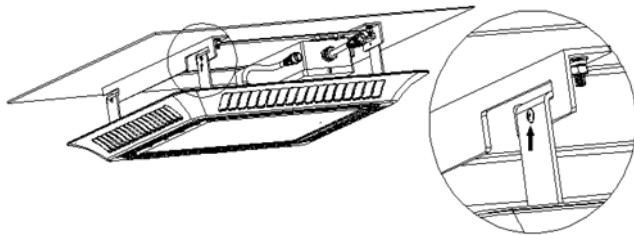

Step 4:

Route luminaire input DC to the DC output of the power supply.

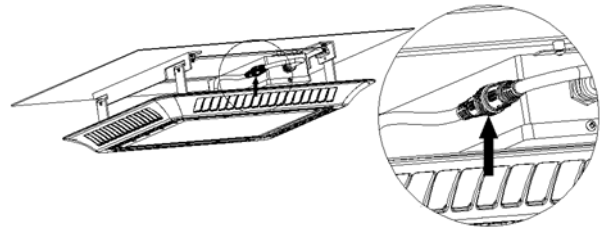

Step 5:

Turn system on, energize circuit breaker and confirm proper luminaire operation.

SUPPLY WIRING

HOT NEU GRND

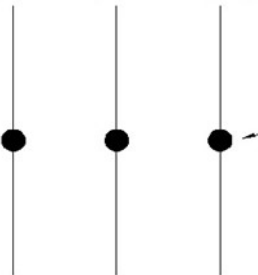

SUITABLE WIRING CONNECTORS

BLK (HOT) WHT (NEU) GRN (GRND)

DRIVER WIRING

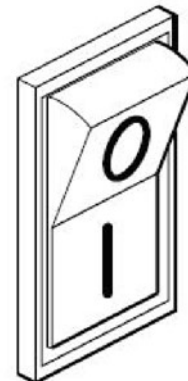



QUALITY ASSURANCE

- ◆ Quality assurance is based on proper storage, transportation and proper packaging, installation, and performing ongoing maintenance
- ◆ Damages caused by human error or improper use are not covered under warranty
- ◆ During the warranty period, the manufacturer will provide appropriate support and repair services as described in the warranty

SAFETY

- ◆ Be aware of product features, size, dimensions, etc. while handling and during installation
- ◆ Handle with care during transportation and installation
- ◆ Do not touch lamps or fixtures while power is on
- ◆ Heat is normal when lamps or fixtures are powered on

WARNING

- ◆ JAYKAL Flood Lights must be installed according to the product spec sheets and instructions, by a lighting or electrical professional
- ◆ Avoid fire and electric shock hazards. When installing the lighting fixtures, one must be familiar with the electrical environment, wiring, etc. Do not install if unsure. Contact your electrician.
- ◆ Prior to installation, be sure to have a sound understanding of all structural features, as well as product dimensions
- ◆ Do not drill new holes or make changes to existing wiring or product design during installation