

User manual of LED Area Light

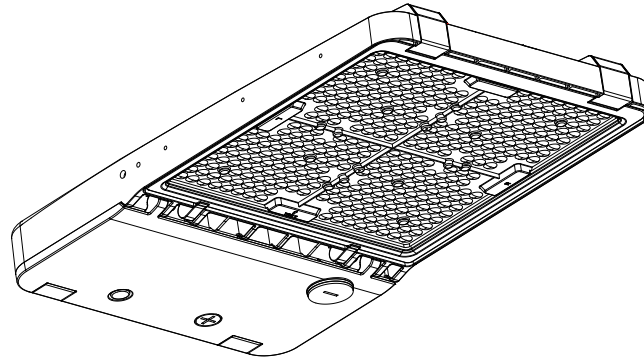

Product Introduction:

Welcome to purchase our led Area Light. Which is with imported high-brightness SMD2835 led chip, with unique high purity die-cast aluminum heat sink, and high efficiency constant current or constant voltage driver. Idea product for the parking lot, street light, road light and similar applications

Product Features:

- ☆ The material of heat sink is high thermal conductivity die-cast aluminum, good for heat dissipation and the surface is anti-static.
- ☆ The unique design of housing help to speed up the heat dissipation, further ensuring the life to the future.
- ☆ The integrated design of appearance makes the fixture looks elegant.
- ☆ This fixture is waterproof, dustproof, and anti-corrosive.

Warning

1. Please read the manual carefully before installation.
2. Please authorize only qualified person or professional engineer to install the fixture.
3. Before installation, please check if the local voltage range is correspond with the working voltage of the fixture.
4. if the fixture is damaged, it should be replaced by a service agent or a qualified person.
5. Please keep the fixture out of fire, electric shock, vibration.
6. To adjust the output power and color temperature, you need to operate after AC OFF

Mounting Options

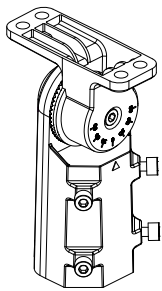

Slip-fitter Bracket

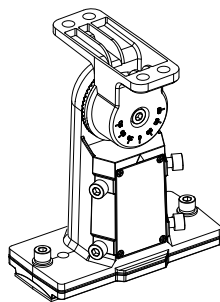

Universal Bracket

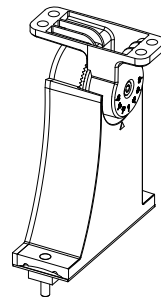

Arm mounting

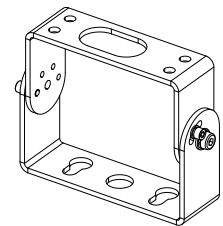

Trunnion mounting

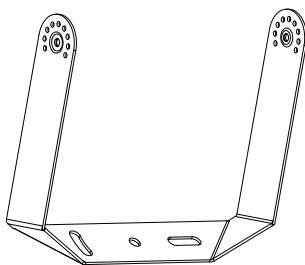

Yoke

Install photo sensor

Photocell

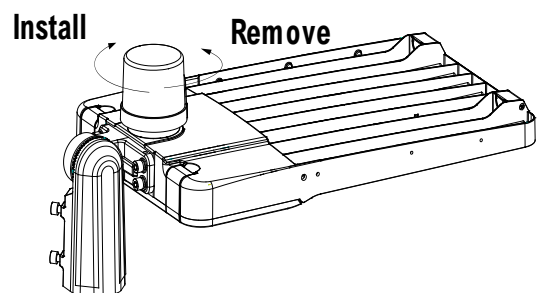

CCT and wattage

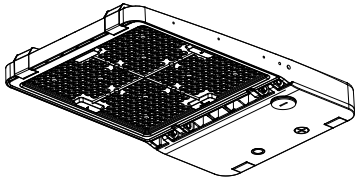

1. Use a flat-blade screwdriver to unscrew the plastic plug.

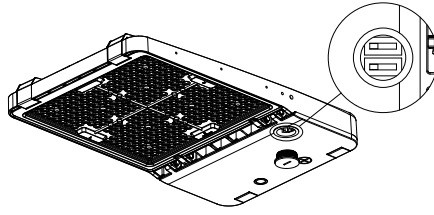

2. Use the slide switch to select the desired wattage and CCT.

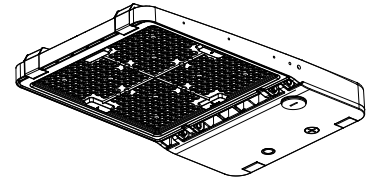

3. Close the plug back, make sure it is well-sealed.

Sensor installation manual

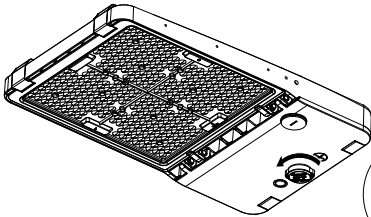

1. Unscrew the ZHAGA/ Sensor base cover.

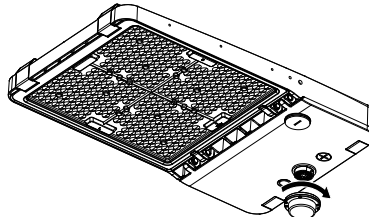
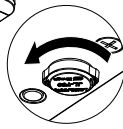

2. Plug and twist the sensor on the base.

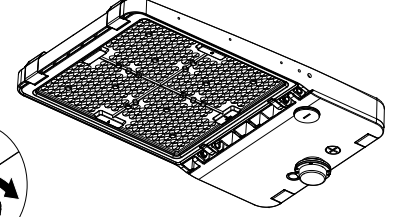
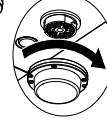

3. Installation complete.

Replace to desired lens

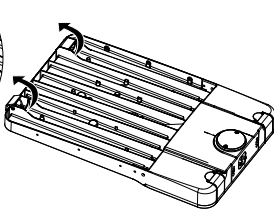

1. Open the two buckles.

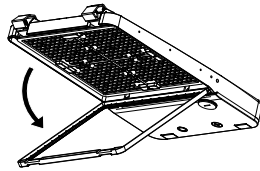

2. Open the lens retaining frame

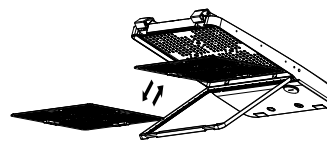

3. Take out the old lens directly and install the required lens

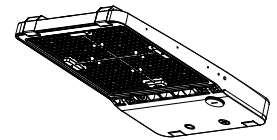

4. Close the lens pressure plate and re-fasten the buckle

Wiring Diagram

AC cord

EU- Standard	US- Standard	label
Brown	Black	L L
Blue	White	N N
Yellow/Green	Green	⊕GND ⊖GND

0-10V dimmable

	label
Purple DIM +	D+ D+
Pink DIM -	D- D-
Black&White +12V	+12V

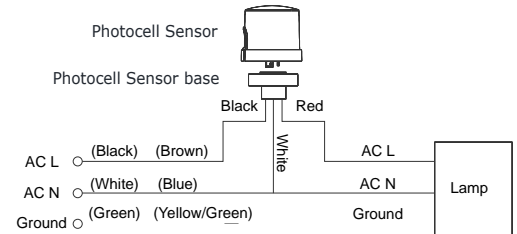

Mini Photocell

When you don't need the function of Mini photocell, please process as below:

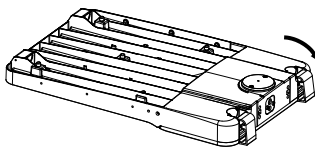

1, Open the buckle and unlock the cover of driver;

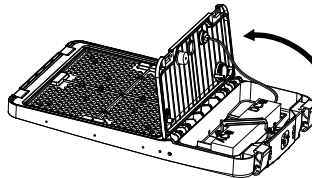

2, Open the cover of driver;

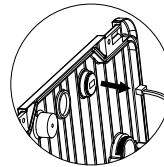

3, Pull out the plug of Mini photocell;

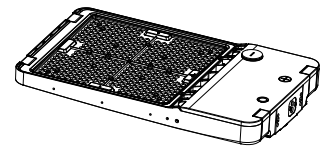

4, Close the cover of driver, fasten the buckle and lock the cover of driver.

Safety rope

Lamp must fasten individual safety cable. (Can be purchased separately as an accessory.)

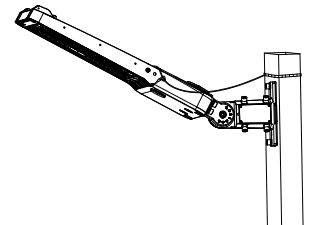
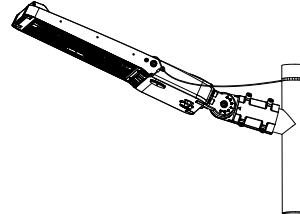
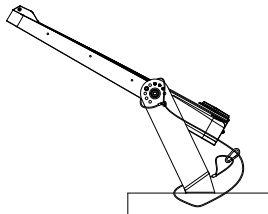
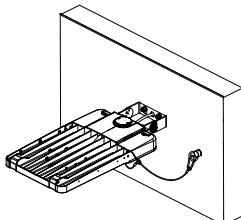

Installation instruction Slip-fitter bracket

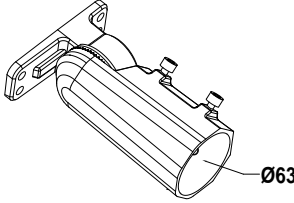
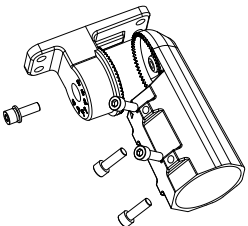
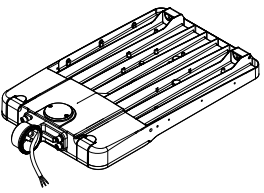
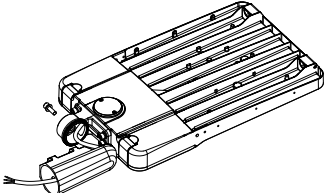
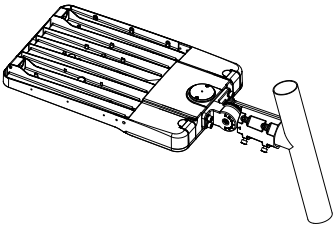
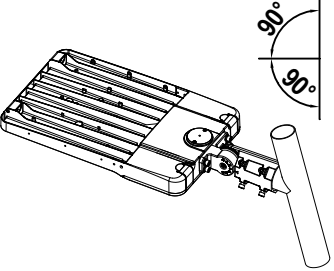
 <p style="text-align: right;">Ø63</p> <p style="text-align: center;">Unit:mm</p>	 <p>1. Split the bracket.</p>	 <p>2. Insert the AC/Dim Wire from the bracket into the base and fix the 4pcs screw on the lamp body.</p>	 <p>3. Insert the AC/Dim Wire into the other part of the bracket, and tighten the large screw.</p>
	<p>4. Make sure the wiring is correct according to the wiring diageam. (L/N/G/ Dim+/Dim-(If have))</p>	 <p>5. Install the lamp post and tighten the 4pcs M8 screw.</p>	 <p>6. Adjust to the required angle through large screws.</p>

Installation instruction Arm mounting bracket

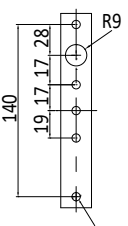
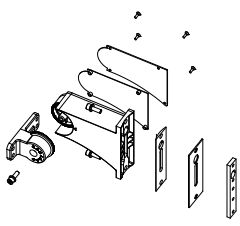
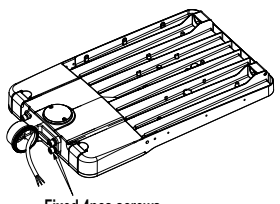
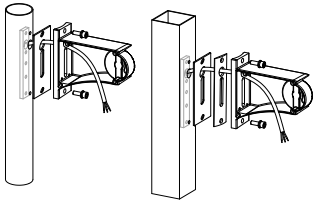
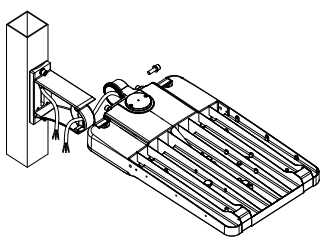
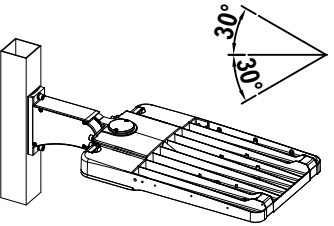
 <p>5-M8 Threaded through</p> <p style="text-align: center;">Unit:mm</p>	 <p>1. Split the bracket.</p>	 <p>Fixed 4pcs screws</p> <p>2. Insert the AC/Dim Wire from the bracket into the base and fix the 4pcs screw on the lamp body.</p>	 <p>3. Fix iron and Rubber Aprons in the lamppost and lock the screws to half.</p>
	 <p>4. Insert the AC/Dim wire into the other part of the bracket, tighten the large screw.</p>	<p>5. Make sure the wiring is correct according to the wiring diageam. (L/N/G/ Dim+/Dim-(If have))</p>	 <p>6. Put the wire into the support chamber and lock the cover. Adjust to the required angle by the large screws.</p>

Installation instruction Trunnion mounting

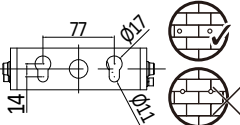
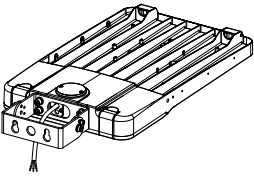
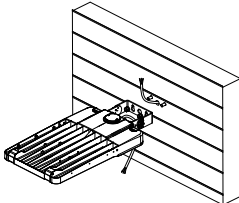
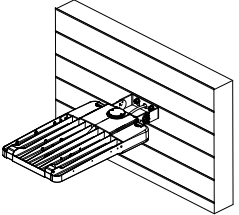
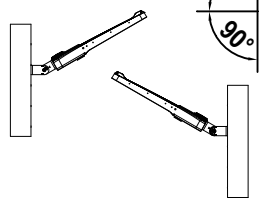
 <p style="text-align: center;">Unit:mm</p>	 <p>1. Insert the AC/Dim wire from the bracket into the base and fix the 4pcs screw on the lamp body.</p>	 <p>2. Drill two holes and insert two Expansion bolt.</p>	 <p>3. Fix the TR bracket on the Expansion bolt with screws. Make sure the wiring is correct according to the wiring diageam.(L/N/G/ Dim+/Dim-(If have))</p>	 <p>4. Unscrew the screws to adjust desired angle if needs.</p>
--	--	--	--	--

Installation instruction Unversial bracket on square/round pole

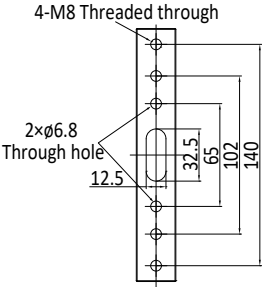
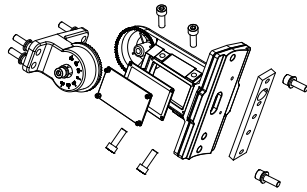
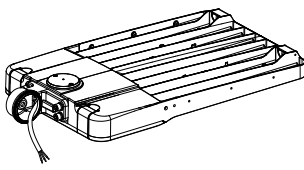
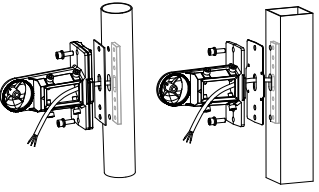
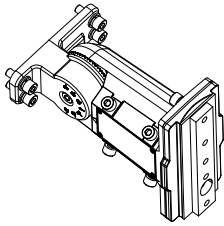
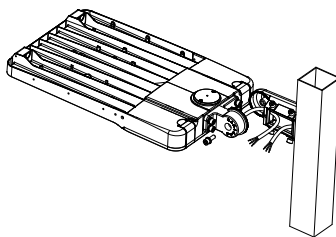
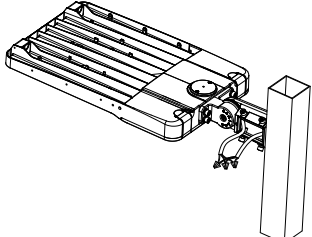
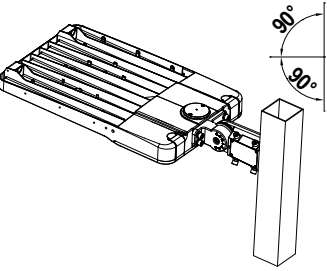
	 <p>1. Split the bracket.</p>	 <p>2. Insert the AC/Dim wire from the bracket into the base and fix the 4pcs screw on the lamp body.</p>	 <p>3. Fix iron and Rubber Silicones in the lamppost and lock the screws to half.</p>
 <p>Unit:mm</p>	 <p>4. Insert the AC/Dim wire into the other part of the bracket, tighten the large screw.</p>	 <p>5. Make sure the wiring is correct according to the wiring diageam. (L/N/G/ Dim+/Dim-(If have)</p>	 <p>6. Put the wire into the support chamber and lock the cover. Adjust to the required angle through large screws.</p>

Installation instruction Unversial bracket on tennon bracket

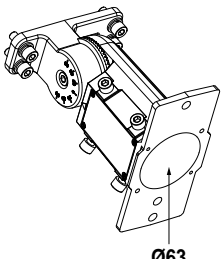
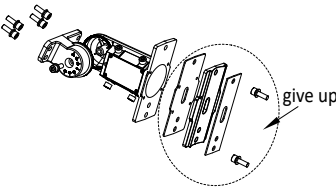
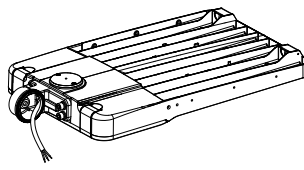
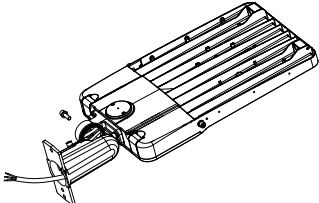
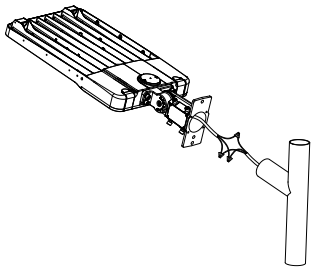
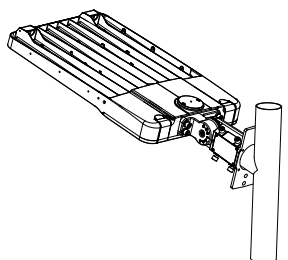
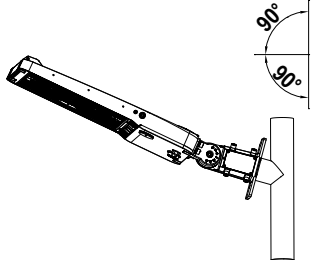
 <p>Ø63</p>	 <p>1. Split the bracket.</p>	 <p>2. Insert the AC/Dim wire from the bracket into the base and fix the 4pcs screw on the lamp body.</p>	 <p>3. Insert the AC/Dim wire into the other part of the bracket, tighten the large screw.</p>
<p>Unit:mm</p>	 <p>4. Make sure the wiring is correct according to the wiring diageam. (L/N/G/ Dim+/Dim-(If have)</p>	 <p>5. Install the lamp post and tighten the 4pcs M8 screw.</p>	 <p>6. Unscrew the screws to adjust desired angle if needs.</p>

Installation instruction Yoke mounting

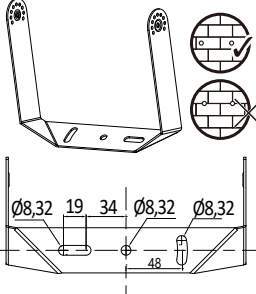
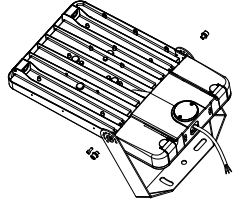
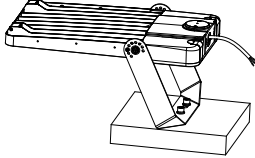
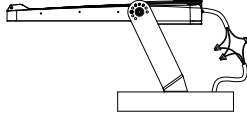
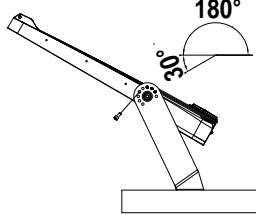
 <p>Unit:mm</p>	 <p>1. fix 3pcs screws on the lamp body.</p>	 <p>2. Drill two holes and insert two Expansion bolts.</p>	 <p>3. Fixed with screws, and then make sure the wiring is correct according to the wiring diageam. (L/N/G/ Dim+/Dim-(If have)</p>	 <p>4. Unscrew the screws to adjust desired angle if needs.</p>
--	---	---	--	--