

# Installation Instruction

## ⚠ WARNING

- To reduce the risk of death, personal injury or property damage from fire, electric shock, falling parts, cuts/abrasions, and other hazards read all warnings and instructions included with and on the fixture box and all fixture labels.
- Before installing, servicing, or performing routine maintenance upon this equipment, follow these general precautions.
- Commercial installation, service and maintenance of luminaires should be performed by a qualified licensed electrician.
- For the installation: If you are unsure about the installation or maintenance of the luminaires, consult a qualified licensed electrician and check your local electrical code.
- To prevent wiring damage or abrasion, do not expose wiring to edges of sheet metal or other sharp objects.
- Do not make or alter any open holes in an enclosure of wiring or electrical components during kit installation.

## ⚠ WARNING

- Turn off electrical power at fuse or circuit breaker box before wiring fixture to the power supply.
- Turn off the power when you perform any maintenance.
- Verify that supply voltage is correct by comparing it with the luminaire label information.
- All wiring connections should be capped with UL approved wire connectors.

## ⚠ CAUTION

- Avoid direct eye exposure to the light source while it is on.
- Account for small parts and destroy packing material, as these may be hazardous to children.
- Risk of burn. Disconnect power and allow fixture to cool before changing bulb or handling fixture.

**NOTICE:** Green ground screw provided in proper location. Do not relocate.

**NOTICE:** Minimum 90° supply conductors.

**NOTICE:** Specifications and dimensions subject to change without notice.

**NOTICE:** Suitable for Dry or Damp location,

## General Wiring Diagram

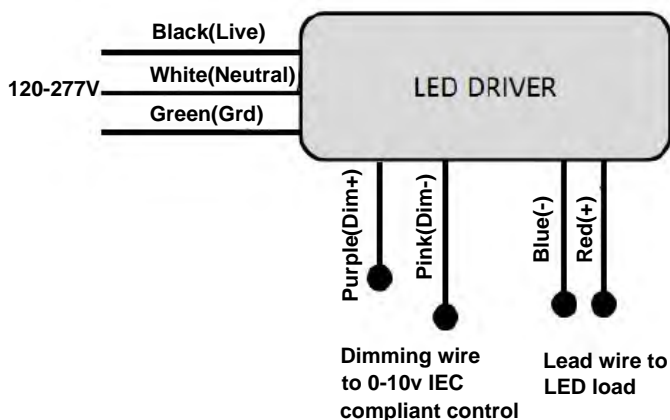

## Component Summary

Part	Qty.
Retrofit housing	2
Installation bracket	3
Lens	2

# Installation Instruction

## NOTICE:

The kits have been tested, fully and properly mounted in a fixture as similar as possible to the kit's intended use.  
Tested Housing Model Number:  
Lithonia C2 32 MVOLT GEB10IS  
Lithonia TC2 32 MVOLT GEB10IS

## Installation Steps:

1. Shut off power to existing fixture. Disconnect power supply wires to existing ballast. Remove and discard the host fixture lamp(s), ballast cover, ballast, socket-bars and wires.

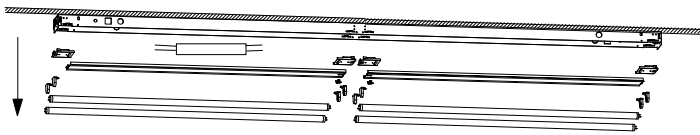

3. Slide the lens at least 4mm to 5mm while depressing one end of the lens past the lens stop inside the end-cap, then remove the lens. Repeat the above actions to remove the lens of the other half fixture.

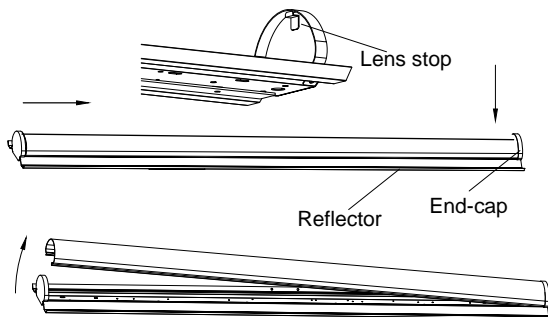

5. Depress and insert the lens past the lens stop inside the end-cap. Snap the lens upward into the reflector track. Carefully slide lens and make sure both ends of the lens are completely wrapped by end-caps. Check and make sure the end-cap perpendicular to the reflector.

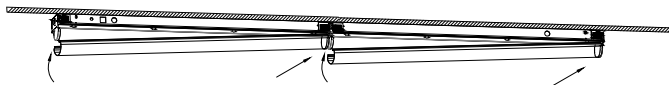

2. Install brackets on both sides and middle of the existing fixture housing with screws.

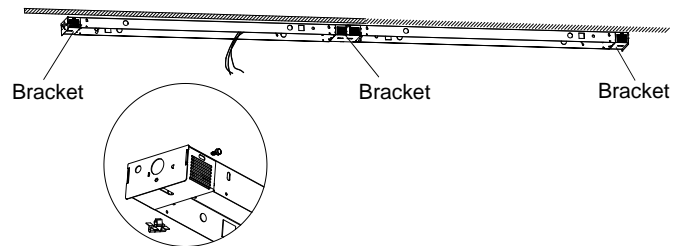

4. Fix the safety cables to the original housing. Hang the LED retrofit assembly with the cables and make electrical connections. Secure the assembly with fixing clips.

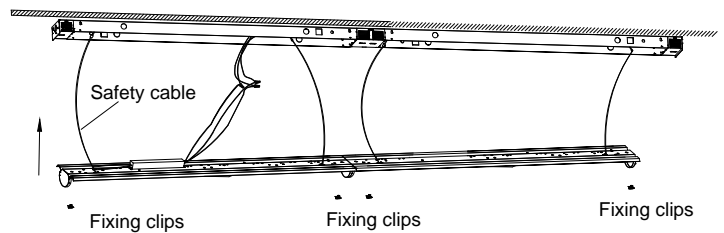

6. Clean lens with non-abrasive cleaning solution. Electrically activate the fixture.

